

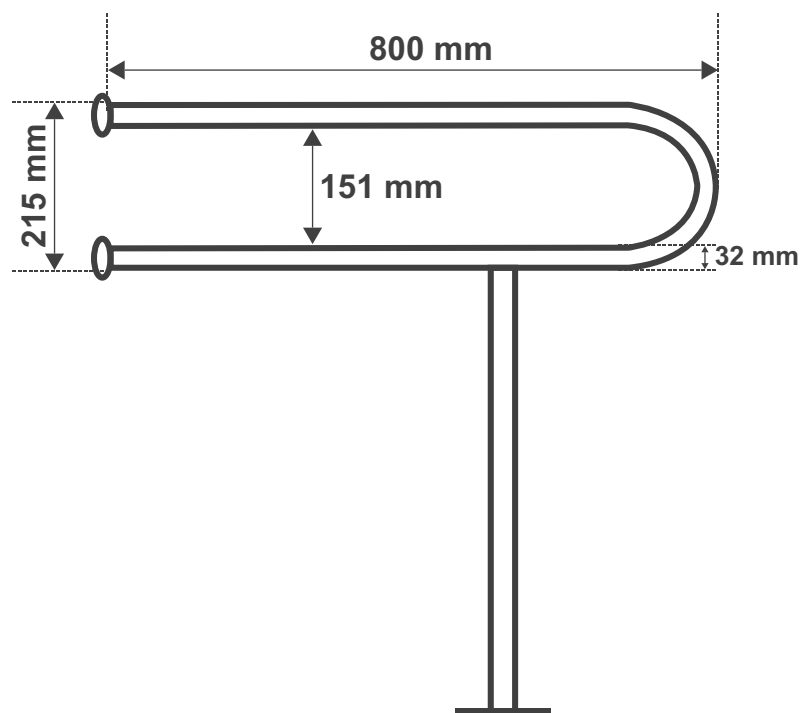

U-Shaped Grab Bar for Handicap People

Model No.: SIGB 03



SPECIFICATIONS

Material	SS-304 Grade
Dimensions	800 x 215 mm
Application	WC Area
Size	800 mm
Fixing	Drill & Fix with Screw

- Self-adhesive PU Tactile Tile
- ADA Braille Signage & Tactile Map
- Fire & Safety Signage
- Accessible Products
- Parking & Warehouse Products
- Road Safety Products

**EXCLUSIVE
RANGE !!**

BEST PRICE! GUARANTEED!

Get a free quote today.

www.signxpressindia.com

All measurements are in mm.

Visit www.signxpressindia.com for a full range of Signxpress India inspire products.

Email
info@signxpressindia.com
connect.signxpressindia@gmail.com

Phone
(+91) 8882221880, (+91) 9810032137
(001) 45527272, (+91) 9810797949

Address
Rz-8 Mahendra Park, Uttam Nagar
East, New Delhi-110059 (India)